

PLC-RSP- 24DC/21-21

Order No.: 2912507



<http://eshop.phoenixcontact.de/phoenix/treeViewClick.do?UID=2912507>

PLC relay, consisting of basic terminal block PLC-BSP.../21-21 with spring-cage connection and pluggable miniature relay with power contact, for assembly on DIN rail NS 35/7.5, 2 PDT, input voltage 24 V DC

Commercial data	
EAN	4046356050913
Pack	10 pcs.
Customs tariff	85364190
Weight/Piece	0.06306 KG
Catalog page information	Page 67 (IF-2007)

Product notes

WEEE/RoHS-compliant since:
04/07/2006



<http://www.download.phoenixcontact.com>
Please note that the data given here has been taken from the online catalog. For comprehensive information and data, please refer to the user documentation. The General Terms and Conditions of Use apply to Internet downloads.

Technical data	
Coil side	
Nominal input voltage U_N	24 V DC
Nominal input current at U_N	18 mA
Typical response time	8 ms

Typical release time	10 ms
Operating voltage display	Yellow LED
Name of protection	Polarity protection
Protective circuit/component	Polarity protection diode

Contact side

Contact type	Single contact, 2-PDT
Contact material	AgNi
Maximum switching voltage	250 V AC/DC (The separating plate PLC-ATP should be installed for voltages larger than 250 V (L1, L2, L3) between identical terminal blocks in adjacent modules. Potential bridging is then carried out with FBST 8-PLC... or ...FBST 500...)
Minimum switching voltage	5 V AC/DC
Maximum inrush current	15 A (300 ms)
Min. switching current	10 mA
Limiting continuous current	6 A
Interrupting rating (ohmic load) max.	140 W (for 24 V DC)
	85 W (for 48 V DC)
	60 W (for 60 V DC)
	44 W (for 110 V DC)
	60 W (for 220 V DC)
	1500 VA (for 250 V AC)

General data

Length	80 mm
Height	94 mm
Width	14 mm
Ambient temperature (operation)	-25 °C ... 60 °C
Ambient temperature (storage/transport)	-40 °C ... 85 °C
Operating mode	100% operating factor
Service life mechanical	3 x 10 ⁷ cycles
Inflammability class in acc. with UL 94 (housing)	V0
Standard designation	Standards/regulations
Standards/regulations	DIN EN 50178/VDE 0160
Pollution degree	2
Surge voltage category	III
Mounting position	Any
Assembly instructions	In rows with zero spacing

Connection data

Type of connection	Spring-cage connection
Conductor cross section solid min.	0.2 mm ²
Conductor cross section solid max.	2.5 mm ²
Conductor cross section stranded min.	0.2 mm ²
Conductor cross section stranded max.	2.5 mm ²
Conductor cross section AWG/kcmil min.	24
Conductor cross section AWG/kcmil max	14
Stripping length	8 mm

Certificates / Approvals

Certifications applied for: UL Listed / CUL Listed

Drawings

Circuit diagram

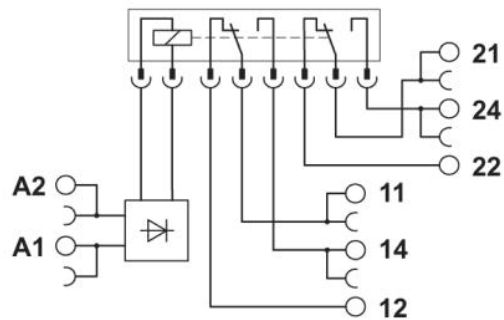

Address

PHOENIX CONTACT Inc., USA
586 Fulling Mill Road
Middletown, PA 17057, USA
Phone (800) 888-7388
Fax (717) 944-1625
<http://www.phoenixcon.com>



© 2009 Phoenix Contact
Technical modifications reserved;